

Size(m)	
TH	
TR	
PIT	2.8
FF(Top floor)	5.05
14F	
13F	
12F	
11F	
10F	
9F	
8F	
7F	
6F	
5F	
4F	
3F	
2F	
FF(resh floor)	
Pro	ND.(m)

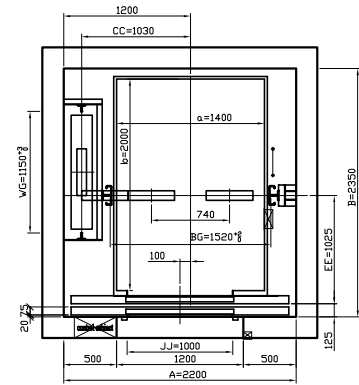

Lift Plan

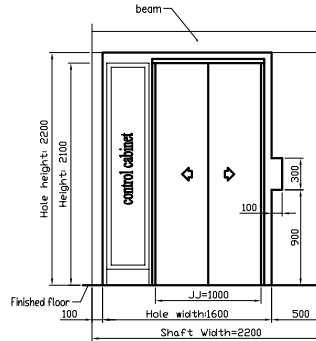

Entrance plan
Top Floor

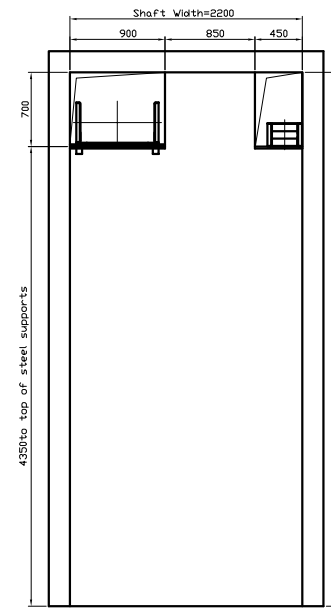

Section A-A

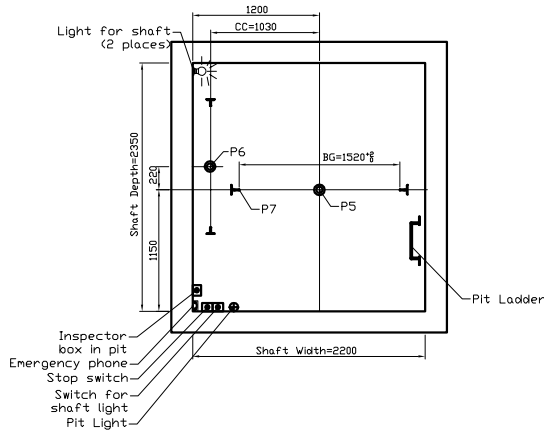

Lift Plan (for installation reference)

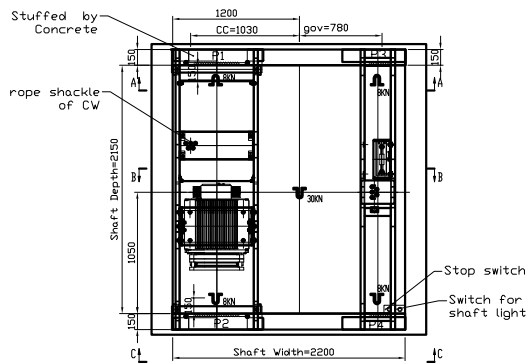

Top Beam Layout (for installation reference)

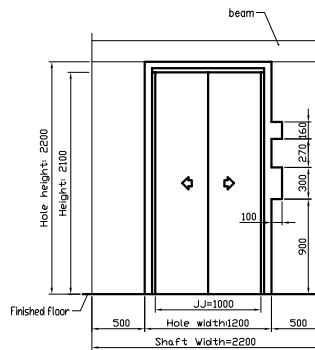

Entrance plan
Main Floor

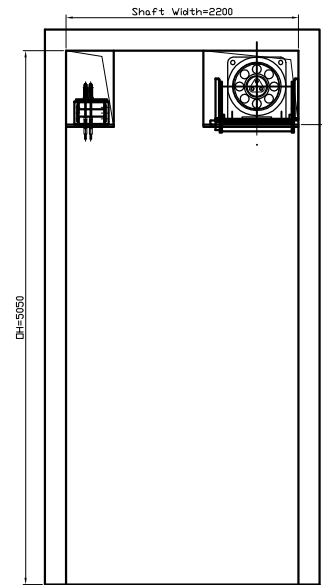

Section B-B

Equipment Specification

Elevator Type	Passenger Lift	
Rated Load	1250kg	
Rated Speed	3.0m/s	
Control Style	Simplex	
Floor/Stop/Door	35/35/35	
Door Open Type	2-panel center	
Door Dimension (W*H) (mm)	1000*2100	
Car Dimension (W*D*H) (mm)	1400*2000*2350	
Suspension	2:1	
Shaft Dimension (W*D) (mm)	2200*2350	
Travel Height (TH)	≤120m	
Pit Depth (PIT)	2800mm	
Shaft Head Height (OH)	5050mm	
Motor	SM250.60B	
HP (KW)	24.5kW	
Traction Rope/Speed governor Rope	10*φ10(Pitch 16)/1*φ8	
Rail	15K(car)/8K(C.W.T)	
Buffer	Oil buffer	
Safety gear	Progressive	
Hall dimension of the upper side of the shaft	1600*2200	
Traction Machine	Outputs	24.5kW
	Rated Current	61.3A
Power Supply	For Power	A.C 3-415V 50HZ
	For light	A.C 1-240V 50HZ
	Capacity (for power)	7.5KVA
	Capacity (for light)	3.3KVA
Force (KN)	P1	95
	P2	100
	P3	31
	P4	27
	P5	100
	P6	82
	P7	27



Austand Elevator Company Ltd

Project:	
Contract No.:	
Type: SLM1250-3.0-CO	Sheet 1 of 4 sheets
Name:	Date:
Designed by: Eva	01/02/2005
Checked by: Tony	01/02/2005
Approved by: Joe	01/02/2005
Edition:	
B	
Draw No.:	
GAD-1250-3.0C-MRL	
Title	
AUSTAND SLM Series(1250kg)	

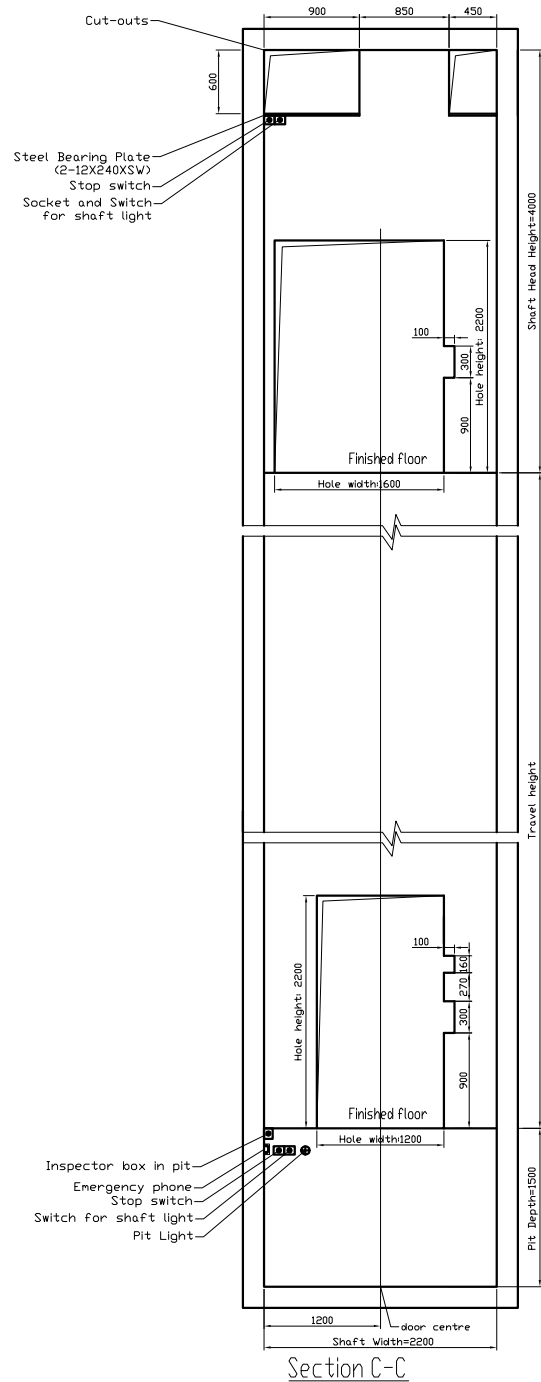

Section C-C

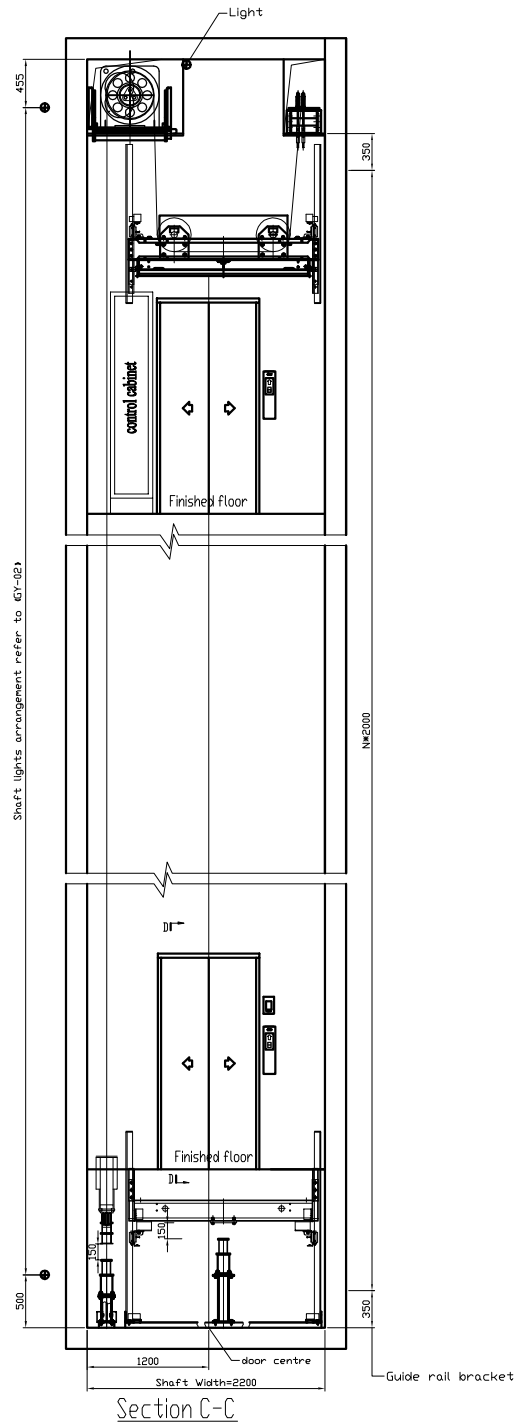

Section C-C



D-D



Austand Elevator Company Ltd

Project:

Contract No.:

Type: SLM1250-3.0-C0

Sheet 2 of 4 sheets

Designed by: Eva 01/02/2005

Checked by: Tony 01/02/2005

Approved by: Joe 01/02/2005

Edition:
B
Draw No. :
GAD-1250-3.0C-MRL

Title: AUSTAND SLM Series(1250kg)

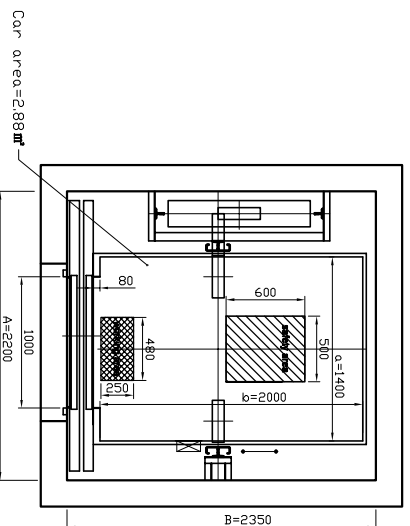
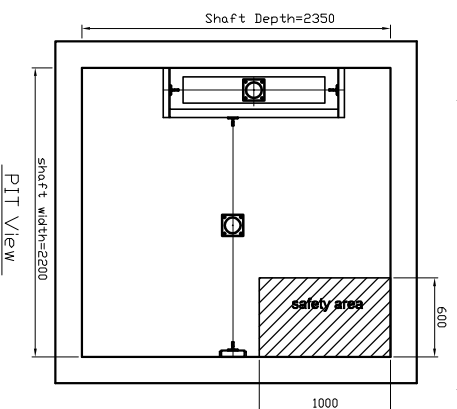
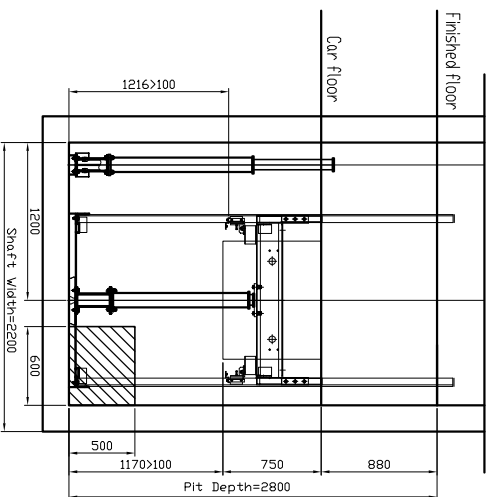
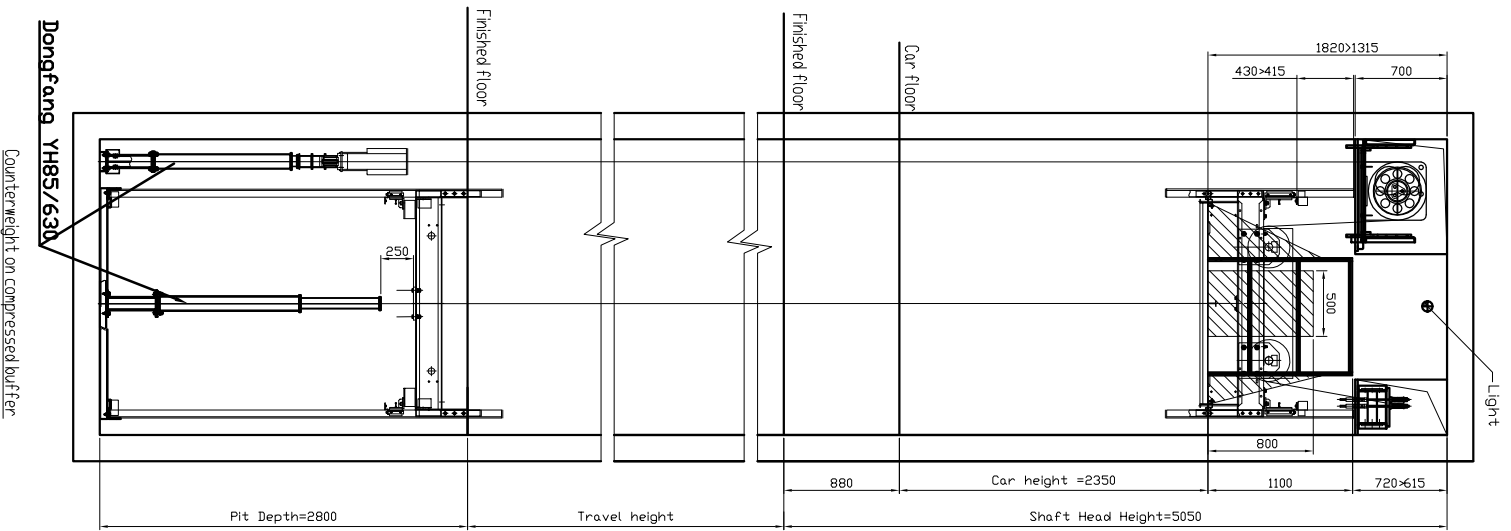

Dongfang YH85/630
Counterweight on compressed buffer

Technical Explanation

1 According to 5.7.2.2c in EN 81, in the car top should have enough space to put a rectangular block which is no less than 0.50m*0.60m*0.80m. Either side to put down is OK.

2 All the dimension unmarked in the drawing should be mm.



Austand Elevator Company Ltd

Project:

Contract No.:

Type: SLM1250-3.0-C0

Sheet 3 of 4 sheets

Name: Eva

Drawng No.:

Date: 01/02/2005

Checked by: Tony

B

GAD-1250-3.0C-MRL

Approved by: Joe

Title

AUSTAND SLM Series(1250kg)

GUIDANCE NOTES

1. Power supply

- (1) The lift power supply shall comply with AS 3000.
- (2) The elevator power supply shall be clearly identified at the main switch board.
- (3) The supply voltage shall fluctuate no more than 7% of the rated voltage.
- (4) Neutral wire and earth wire shall be supplied.

2. Pit

- (1) A waterproof pit shall be provided complete with a dry, covered sump. The pit should be graded toward the sump.
- (2) The pit shall extend to solid ground.

3. Shaft

- (1) The lift shaft for each elevator should be totally enclosed with only the following openings, Shaft door openings, Button and indicator openings, Ventilation if required.
- (2) The walls, of the lift shaft shall be of solid material and suitable for expansion type fixings.
- (3) The top of the lift shaft shall be insulated equal to R2.
- (4) The lift shaft is not to be used for other services.
- (5) The deviation allowed for the shaft wall are
 - 0~+25mm for height not more than 30m
 - 0~+35mm for height not more than 60m
 - 0~+50mm for height not more than 90m
- (6) Lifting hooks at the top of the shaft.
- (7) support angles for machine beams at top of shaft.

 Austand Elevator Company Ltd			
Project:			
Contract No.:			
Type: SLM1250-3.0-CO			Sheet 4 of 4 sheets
	Name:	Date:	Edition:
Designed by:	Eva	01/02/2005	B
Checked by:	Tony	01/02/2005	
Approved by:	Joe	01/02/2005	
			Drawg No. : GAD-1250-3.0C-MRL
Title AUSTAND SLM Series(1250kg)			